

313104

EF12GG9

CUCINA GAS 6 FUOCHI CON FORNO GAS GN2/1

6 BURNERS GAS RANGE WITH GN2/1 GAS OVEN

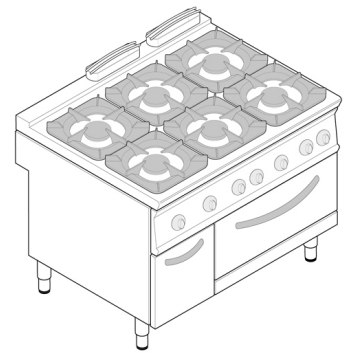

CARATTERISTICHE TECNICHE

* Guide portateglie e suola forno smaltate e rimovibili

TECHNICAL SPECIFICATIONS

* Bottom and runners for backing trays are enamelled and removable



Information shown is provided only as a guide. The company reserves the right to modify these data without notifying anytime. La validità dei dati riportati è indicativa. L'Azienda si riserva il diritto di apportare, in qualsiasi momento, variazioni anche senza preavviso.

TECNOINOX SRL | VIA TORRICELLI, 1 | 33080 PORCIA (PN) ITALY | T +39 0434 920110 | F +39 0434 920422 | TECNOINOX@TECNOINOX.IT | WWW.TECNOINOX.IT

313104**EF12GG9**

CUCINA GAS 6 FUOCHI CON FORNO GAS GN2/1

6 BURNERS GAS RANGE WITH GN2/1 GAS OVEN

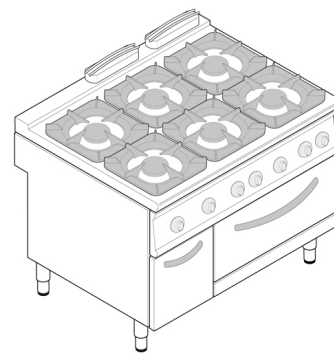
**DATI TECNICI / TECHNICAL SHEET**

| | | |
|---|--------|-------------------|
| Potenza / Power | kW | 55 |
| Potenza Forno / Oven Power | kW | 7 |
| Potenza Fuochi Aperti / Open Burners Power | n°x kW | 6x8 |
| Potenza Piano / Top Power | kW | 48 |
| Capacità Teglie / Trays capacity | n°x | 4xGN2/1 |
| Consumo GAS Metano / Natural Gas Consumption | m³/h | 5,81 |
| Dimensione Camera Forno (LxPxH) / Oven Chamber Dimensions (WxDxH) | cm | 57,5x65x30 |
| Dimensione Forno / Oven dimension | | GN2/1 |
| Dimensione Vano (LxPxH) / Cabinet inner Dimensions (WxDxH) | cm | 33x76,1x39,5 |
| Guide / Runners | n° | 4 |
| Numero Bruciatori / Number of Burners | n° | 6 |
| Passo Teglie / Distance between shelves | cm | 6 |
| Range Temperatura Forno / Oven Temperature Range | °C | 150÷290 |
| Supporti Pentola / Pan Holders | | Ghisa Smalto RAAF |
| Tipo Forno / Oven Version | | Statico |
| Larghezza / Width | cm | 120 |
| Profondità / Depth | cm | 90 |
| Altezza / Height | cm | 90 |
| Larghezza Imballo / Packaging Width | cm | 126,0 |
| Profondità Imballo / Packaging Depth | cm | 100,0 |
| Altezza Imballo / Packaging Height | cm | 116,0 |
| Peso Netto / Net Weight | kg | 140,8000 |
| Peso Lordo / Gross Weight | kg | 167,0000 |
| Volume / Volume | m³ | 01,4600 |



Information shown is provided only as a guide. The company reserves the right to modify these data without notifying anytime. La validità dei dati riportati è indicativa. L'Azienda si riserva il diritto di apportare, in qualsiasi momento, variazioni anche senza preavviso.