

# 313159

# PCGM12FG 9/1

## PIANO COTTURA GAS 3 FUOCHI SU VANO APERTO

### 3 BURNERS FREESTANDING GAS BOILING TOP

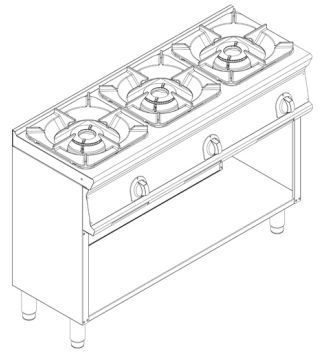

#### CARATTERISTICHE TECNICHE

- \* Costruito in acciaio inox
- \* Dotata di piedi regolabili, può essere disposta a parete o ad isola
- \* Vano attrezzabile con porte
- \* Funzionamento a gas metano o liquido; in dotazione ugelli intercambiabili
- \* Cassetti recupero residui posti al di sotto dei bruciatori dei fuochi aperti
- \* Comandi e componenti facilmente accessibili rimuovendo il cruscotto
- \* Rubinetti valvolati
- \* Bruciatori a gas in ghisa smaltata vetrificata, dotati di fiamma pilota e termocoppia di sicurezza
- \* Bruciatori doppia corona

#### TECHNICAL SPECIFICATIONS

- \* Made of stainless steel
- \* Equipped with adjustable feet. It can be positioned by the wall or combined with other appliances as a central island.
- \* The base unit can be equipped with doors
- \* Natural gas or LPG functioning; interchangeable nozzles are provided
- \* Residue collection drawer positioned underneath the burners
- \* Easy to reach controls and units thanks to the removable front panel
- \* Safety gas valves
- \* Gas burners made of vitreous enamelled cast iron equipped with pilot flame and safety thermocouple
- \* Burners featuring double crown



Information shown is provided only as a guide. The company reserves the right to modify these data without notifying anytime. La validità dei dati riportati è indicativa. L'Azienda si riserva il diritto di apportare, in qualsiasi momento, variazioni anche senza preavviso.

**313159****PCGM12FG  
9/1**

PIANO COTTURA GAS 3 FUOCHI SU VANO APERTO

3 BURNERS FREESTANDING GAS BOILING TOP

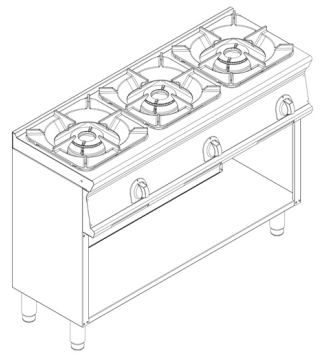
**DATI TECNICI / TECHNICAL SHEET**

Potenza / Power	kW	27
Potenza Fuochi Aperti / Open Burners Power	n°x kW	3X9
Potenza Piano / Top Power	kW	27
Consumo GAS Metano / Natural Gas Consumption	m³/h	2,85
Dimensione Vano (LxPxH) / Cabinet inner Dimensions (WxDxH)	cm	113X34X39,5
Numero Bruciatori / Number of Burners	n°	3
Supporti Pentola / Pan Holders		Ghisa Smalto RAAF
Larghezza / Width	cm	120
Profondità / Depth	cm	45
Altezza / Height	cm	90
Larghezza Imballo / Packaging Width	cm	125
Profondità Imballo / Packaging Depth	cm	52
Altezza Imballo / Packaging Height	cm	115
Peso Netto / Net Weight	kg	72
Peso Lordo / Gross Weight	kg	82
Volume / Volume	m³	0,74



Information shown is provided only as a guide. The company reserves the right to modify these data without notifying anytime. La validità dei dati riportati è indicativa. L'Azienda si riserva il diritto di apportare, in qualsiasi momento, variazioni anche senza preavviso.