



# Mix



## PANE BAKERY

CE EAC

IT	EN
<b>CARATTERISTICHE TECNICHE:</b>	<b>FEATURES:</b>
<p><b>STRUTTURA</b></p> <ul style="list-style-type: none"> <li>Basamento in tubolare d'acciaio verniciato con polveri epossidiche a forno a 180°C con elementi di irrigidimento e piedini regolabili.</li> <li>Versione pane con cassetto raccogli briciole in acciaio inox AISI 304 finitura Scotch-Brite e vassoi asportabili in multistrati di betulla.</li> <li>Piano lavoro lato operatore profondo 193 mm in acciaio inox AISI 304 finitura Scotch-Brite.</li> <li>Parete posteriore lato operatore e fianchi laterali della vasca in acciaio inox AISI 304 finitura Scotch-Brite.</li> </ul> <p><b>CASTELLO VETRI</b> Il castello vetri è disponibile in quattro configurazioni:</p> <ul style="list-style-type: none"> <li>VAC = vetro alto curvo</li> <li>VAD = vetro alto dritto</li> <li>VBD H 1151 = vetro basso dritto</li> <li>VBD-R20 H 1151 = vetro basso dritto unito al cappello con raggio 20 mm</li> </ul> <p>In tutte le configurazioni il vetro frontale è temperato e apribile con sistema ribaltabile a lato cliente. Fianchi laterali a filo della struttura in vetro trasparente. Illuminazione LED.</p> <ul style="list-style-type: none"> <li>Due mensole in dotazione nelle versioni VAC e VAD, una sola mensola nelle versioni VBD, sorrette da supporti in policarbonato trasparente. Le mensole intermedie sono leggermente più corte della vetrina lasciando una fessura di 15 mm per lato per agevolare le operazioni di pulizia.</li> <li>È possibile sostituire una mensola con la mensola calda (optional).</li> <li>Chiusura posteriore con scorrevoli in plexiglas dotati di maniglia in policarbonato trasparente incassata, a garanzia di una chiusura igienica.</li> </ul> <p>Temperatura ambiente.</p>	<p><b>STRUCTURE</b></p> <ul style="list-style-type: none"> <li>Tubular steel frame, painted with epoxy powders at 180°C with stiffening elements and adjustable feet.</li> <li>Bakery display case with bread crumb tray in AISI 304 stainless steel, Scotch-Brite finish, and removable trays in birch plywood.</li> <li>The AISI 304 stainless steel working top with Scotch-Brite finish is 193 mm deep.</li> <li>Rear wall and tank lateral sides in AISI 304 stainless steel Scotch-Brite finish.</li> </ul> <p><b>GLASS FRAME</b> Glass frame is available on all units with four different settings:</p> <ul style="list-style-type: none"> <li>VAC = curved high glass</li> <li>VAD = straight high glass</li> <li>VBD H 1151 = straight low glass</li> <li>VBD-R20 H 1151 = low straight glass joined to the upper top with a radius of 20 mm</li> </ul> <p>The temperate front glass can be opened with folding system on customer side. On-the-edge lateral sides in transparent. LEDs lighting.</p> <ul style="list-style-type: none"> <li>Two shelves provided in the high glass versions (VAC and VAD) and one shelf in the low glass version (VBD). The intermediate shelves are slightly shorter, leaving a gap (15 mm on each side) between the glass side to facilitate cleaning.</li> <li>As option, glass hot shelf instead of one shelf.</li> <li>The plexiglas sliding doors on the operator's side are equipped with a transparent polycarbonate built-in handle to guarantee hygienic closing.</li> </ul> <p>Ambient temperature.</p>

### SEZIONI MIX PANE MIX BAKERY DISPLAY CASE SECTION VIEWS

**VAC H 1350 MIX**

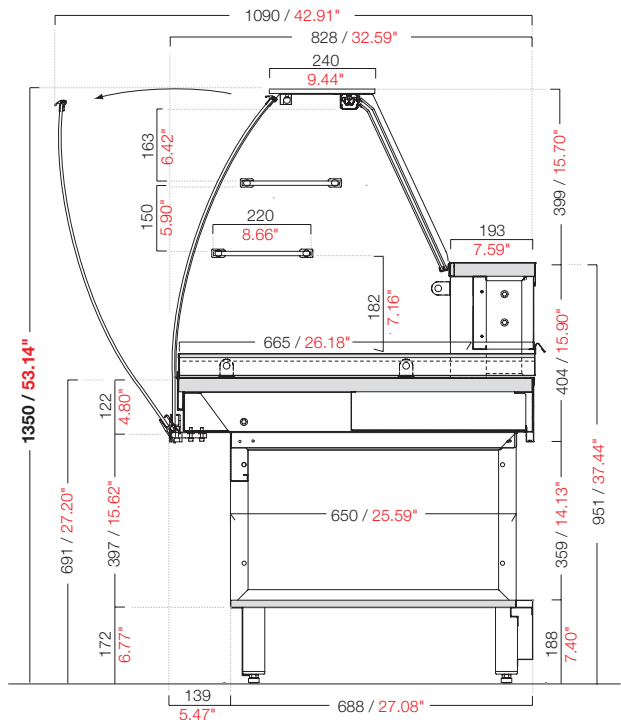

**VAD H 1350 MIX**

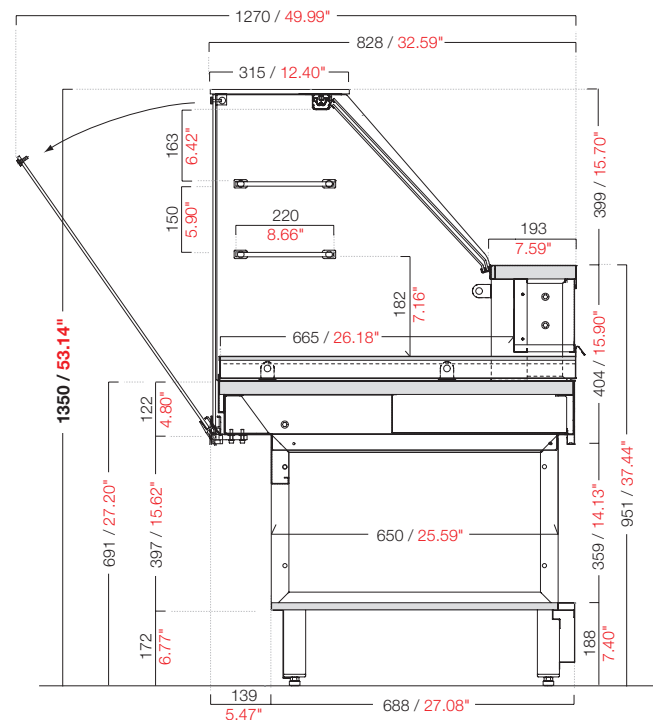



Mix



PANE  
BAKERY

CE EAC

SEZIONI MIX PANE MIX BAKERY DISPLAY CASE SECTION VIEWS

VBD H 1151 MIX

VBD-R20 H 1151 MIX

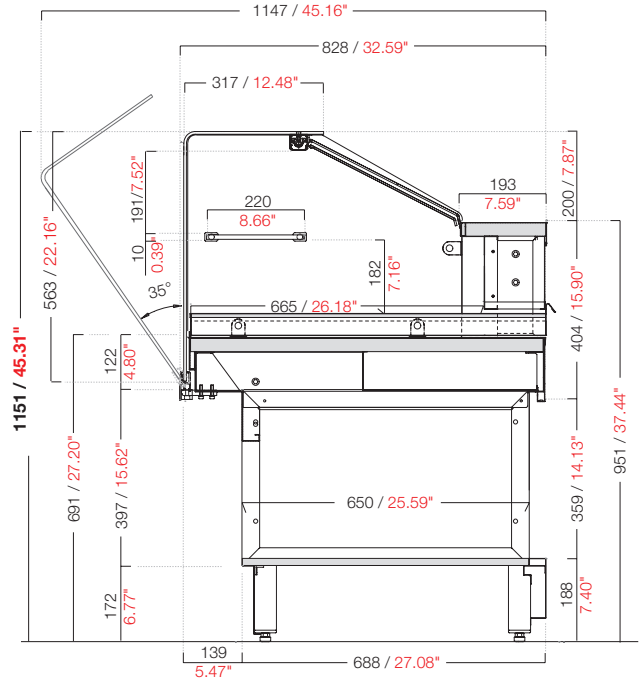
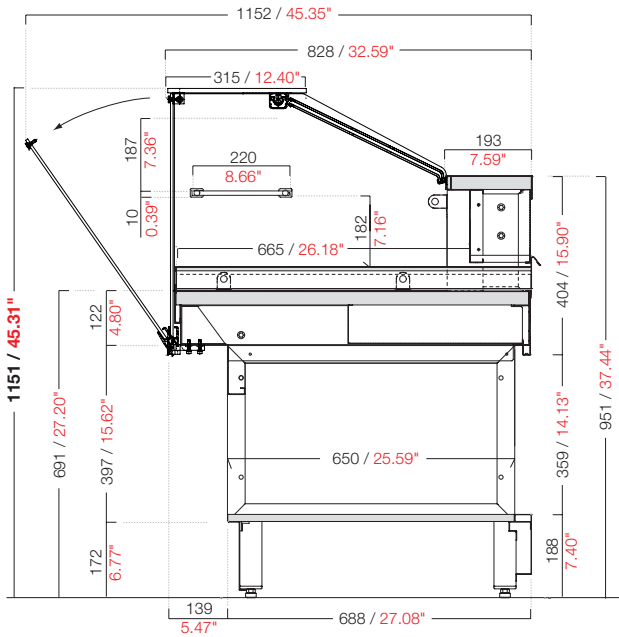

DIMENSIONI - PESO - IMBALLO | DIMENSIONS - WEIGHT - PACKAGING

Modello Unit	Lunghezza Length		Profondità Depth		Peso Weight		Dimensioni imballo LxPxA Packaging dimensions LxDxH		Peso totale prodotto+imballo Total weight product+packaging	
	mm	in	mm	in	kg	lb	mm	in	kg	lb
L 1000	1000*	39.37*	828	32.59	130	287	1124x911xH1367	44,3"x35,9"xH53,8"	167	368
L 1250	1250*	49.21*	828	32.59	150	331	1624x911xH1367	63,9"x35,9"xH53,8"	201	443
L 1500	1500*	59.05*	828	32.59	170	375	1624x911xH1367	63,9"x35,9"xH53,8"	221	487

\*Misure senza fianchi (1 fianco in metallo: 3 mm - 1 fianco in legno: 20 mm)

\*Side panels not included (1 metal side panel: 3 mm - 1 wooden side panel: 20 mm)

Modello Unit	Potenza assorbita Current consumption	
	W	A
L 1000	20	0,09
L 1250	25	0,11
L 1500	30	0,13

