



Cloud

VETRINA GELATO / 4 STAGIONI GELATO / 4-SEASONS DISPLAY CASE



IT	EN
CARATTERISTICHE TECNICHE:	FEATURES:
<p>STRUTTURA</p> <ul style="list-style-type: none"> Struttura portante inferiore in tubolare d'acciaio verniciato con polveri epossidiche a forno a 180°C con elementi di irrigidimento e piedini regolabili. Rivestimento esterno a gradoni in lamiera zincata verniciata bianca a polveri epossidiche con illuminazione LED RGB integrata nel gradone sopra lo zoccolo. Scocca monoblocco con spessore minimo di 50 mm schiumata con poliuretano iniettato a bassa densità (40 Kg/mc), con schienale lato operatore rivestito in acciaio inox AISI 304 finitura lucida BA. Piano lavoro lato operatore schiumato con poliuretano iniettato a bassa densità (40 Kg/mc) e rivestito in acciaio inox AISI 304 finitura lucida BA. Fianchi esterni sagomati in pietra acrilica di colore bianco, spessore 12 mm. Interno vasca (piano e schienale) rivestito in vetro bianco temperato retro illuminato con LED RGB tramite centralina elettronica: grazie al telecomando è possibile impostare qualsiasi colore. L'illuminazione della vasca e dello zoccolo sono controllate dalla stessa centralina. Struttura porta vaschette in acciaio inox AISI 304 finitura lucida BA con segna gusti in vetro integrato ed etichette segna gusti in Plexiglas incluse nel prezzo. La struttura accoglie vaschette su doppia fila da 360x165 mm o da 360x250 mm che poggiano su carter longitudinali posteriori ed anteriori e su un tubo di sostegno centrale, con distanziali che bloccano le vaschette. N° 36 etichette segna gusti in Plexiglas. Fianchi esterni sagomati in pietra acrilica di colore bianco, spessore 12 mm. 	<p>STRUCTURE</p> <ul style="list-style-type: none"> Lower supporting structure in tubular steel painted in epoxy powder and stove-enamelled at 180° with stiffening parts and adjustable legs. Stepped exterior covering in galvanised plate painted in white epoxy powder with RGB LED lighting integrated in the step above the plinth. Monobloc body at least 50 mm thick insulated with injected low-density polyurethane foam (40 kg/m³), and the back panel on the operator side covered with AISI 304 stainless steel with BA polished finish. Worktop on the operator side insulated with injected low-density polyurethane foam (40 kg/m³) and covered with AISI 304 stainless steel, BA polished finish. Shaped exterior side panels in 12mm-thick white acrylic stone. Tank interior (surface and back panel) covered with tempered white glass with RGB LED backlighting by means of an electronic control unit: the remote control allows setting any colour. Tank and plinth lighting is controlled by the same control unit. Pan-holding structure in AISI 304 stainless steel with BA polished finish with integrated glass flavour marker with Plexiglas labels. The structure can hold two rows of pans (360x165xH150 mm or 360x250xH150 mm) which rest on rear and front longitudinal cases and on a central support tube with spacers that hold the pans in place. N.36 black painted Plexiglas labels. 12mm-thick side panels in acrylic stone.
<p>CLOUD gelato/4 stagioni è disponibile nei moduli lineari 1200, 1700 e 2200 mm (senza fianchi; con fianchi 1224, 1724 e 2224 mm), con altezza 1148 mm.</p>	<p>CLOUD display case is available in 1200, 1700 and 2200 mm linear units (without side panels; 1224, 1724, 2224 with side panels) with a height of 1148 mm.</p>
<p>CASTELLO VETRI Castello vetri autoportante con struttura in alluminio lucido brillantato e plafoniera superiore con illuminazione a LED. Vetro frontale camera, pirolettico, riscaldato e temperato con apertura assistita dal basso verso l'alto per mezzo di 4 pistoni a gas. Fianchi in vetro camera pirolettico, riscaldato e temperato. Due sistemi di chiusura lato operatore:</p> <ol style="list-style-type: none"> vetro temperato e riscaldato, per mezzo di serigrafia conduttiva, con apertura assistita per mezzo di pistoni a gas: il vetro ruota e si posiziona orizzontalmente alla vetrina fungendo da piano da appoggio quando la vetrina è in uso; ante scorrevoli in metacrilato, spessore 8 mm, con guarnizioni laterali a tenuta ermetica e maniglie in metallo cromato. 	<p>GLASS FRAME Self-supporting glass frame with polished aluminium structure and LED top lighting. Double-glazed, pyrolytic, heated and tempered glass front with assisted upward opening by means of 4 gas pistons. Double-glazed, pyrolytic, tempered and heated glass sides. Two different closure systems on the operator's side:</p> <ol style="list-style-type: none"> glass panel tempered and heated by means of conductive screen-printing with assisted opening by means of gas pistons: the glass panel turns and positions horizontally to the display case acting as support surface when the case is in use; Plexiglas sliding doors, 8 mm thick, with airtight side seals and chrome-plated handles.
<p>SISTEMA DI CHIUSURA HCS (Hi-performance Closure System) La vetrina gelato CLOUD è dotata di sistema di chiusura ermetica HCS che consente di conservare il gelato dentro la vetrina senza necessità di riporio in armadi o celle refrigerate a bassa temperatura. Il sistema HCS è composto da:</p> <ul style="list-style-type: none"> vetro lato operatore che chiude ermeticamente sulla guarnizione in silicone; oppure scorrevoli in metacrilato trasparente con guarnizioni laterali in PVC a tenuta ermetica; sensori di chiusura che rilevano quando la vetrina è chiusa; sistema di sbrinamento a tempo RDF (Reduced Defrosting Frequency) che riduce il numero di sbrinamenti in base al tempo effettivo di apertura della vetrina. <p>Grazie al sistema HCS lo sbrinamento avviene solamente quando necessario creando le condizioni per una perfetta conservazione del prodotto (meno stress sul gelato) e un relativo risparmio energetico.</p>	<p>HCS CLOSURE SYSTEM (Hi-performance Closure System) The CLOUD gelato display case is equipped with the HCS closure system that allows preserving the gelato in the display case without needing to store it in chiller cabinets or refrigerated cells at low temperature. The HCS system is composed of:</p> <ul style="list-style-type: none"> glass panel on the operator's side that hermetically closes on the silicon seal; or transparent methacrylate sliding doors with airtight PVC side seals; closing sensors that detect when the display case is closed; RDF (Reduced Defrosting Frequency) timed defrosting system to reduce the number of defrosts based on the actual opening time of the display case. <p>Thanks to the HCS system, the display case is defrosted only when necessary, creating the conditions for perfect gelato preservation (less stress on the gelato) and a relative energy saving.</p>
<p>REFRIGERAZIONE L'impianto di refrigerazione ventilato con doppio evaporatore e flusso sopraelevato garantisce omogeneità di temperatura in vasca. La vetrina è dotata di due evaporatori per garantire una maggiore autonomia di ore di lavoro continuo. Lo sbrinamento rapido (automatico a gas caldo con unità condensatrice a bordo, inversione di ciclo con unità condensatrice remota) è differenziato tra evaporatore anteriore ed evaporatore posteriore: ciclo di 4 ore per quello anteriore e di 12 ore per quello posteriore. La fine dello sbrinamento è controllata da una sonda dedicata posta sull'evaporatore. Pannello comandi elettronico per la gestione dell'impianto refrigerante ed elettrico, con ripetitore digitale di temperatura all'interno della vetrina a vista del cliente. CLOUD è testata a 35°C e 60% U.R. Temperatura di esercizio -2°C/-18°C.</p>	<p>REFRIGERATION The ventilated refrigeration system with double evaporator and raised flow ensures homogeneous temperature in the tank. The display case is equipped with two evaporators to ensure greater autonomy of continuous operation. Fast defrosting (automatic with hot gas and onboard condenser unit, cycle inversion with remote condenser unit) is differentiated between the front and the rear evaporator: a cycle of 4 hours for the front and 12 hours for the rear one. The end of defrosting is controlled by a dedicated sensor on the evaporator. Electronic control panel for refrigeration and electric system management with digital temperature repeater in the display case facing the customer. CLOUD is tested at 35°C and 60% RH. Operating temperature -2°C/-18°C.</p>
<p>VERSIONE "4 STAGIONI" La vetrina gelato CLOUD è disponibile anche nella versione "4 STAGIONI": grazie al pulsante di commutazione è possibile con un semplice "click" passare dalla funzione gelateria "BT" (= temperatura negativa -2°C/-18°C) alla funzione pasticceria o snack "TN" (= temperatura positiva +4°C/+8°C). Optional il piano espositivo in acciaio inox da sostituire alle vaschette gelato, necessario quando la vetrina funziona come pasticceria o snack.</p>	<p>"4-SEASONS" VERSION The CLOUD gelato display case is also available in the 4-SEASONS VERSION: the toggle switch allows with just a click changing from the BT gelato (= negative temperature -2°C/-18°C) to the TN pastry or snack function (= positive temperature +4°C/+8°C). Optional stainless steel display top instead of the gelato pans, necessary when the display case is used for pastries or snacks.</p>





Cloud

VETRINA GELATO / 4 STAGIONI GELATO / 4-SEASONS DISPLAY CASE



SEZIONI | SECTION VIEWS

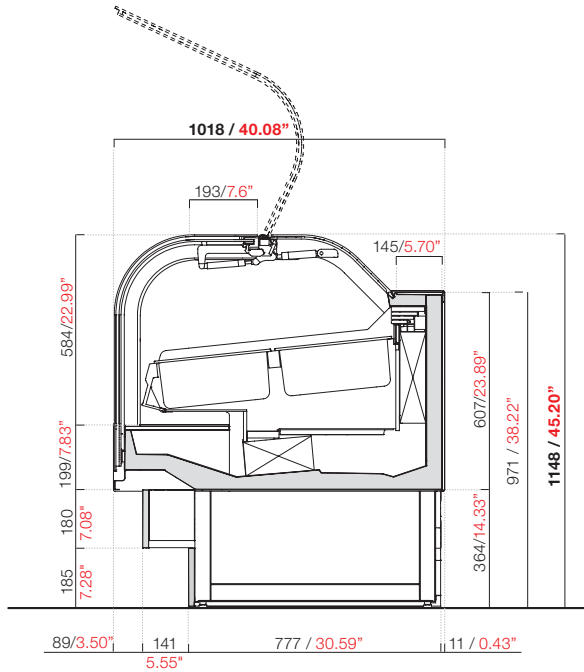

CHIUSURA LATO OPERATORE CON SCORREVOLI HCS
HCS PLEXIGLAS SLIDING DOORS on operator's side

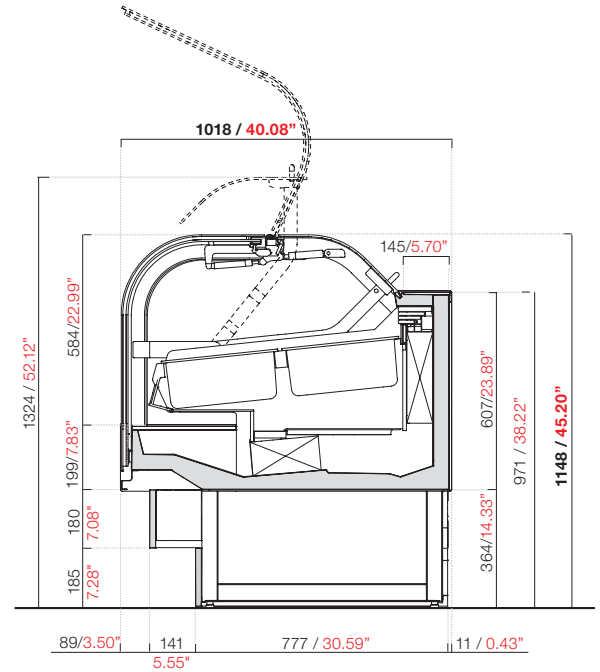

CHIUSURA LATO OPERATORE CON VETRO HCS
HCS GLASS PANEL on operator's side

SCHEMA SCARICHI | DRAINAGES SYSTEM SCHEME

- A - Tubo mandata Ø 12
- B - Tubo aspirazione Ø 22 (pasticceria BT/4 stagioni)
- B - Tubo aspirazione Ø 16 (gelato/gelato 4 stagioni)
- SC - Scarico condensa con valvola antiriflusso 3/4"
- E - Alimentazione elettrica per vetrina
- EU - Alimentazione elettrica per UC remota

- A - Delivery tube Ø 12
- B - Aspiration tube Ø 22 (BT pastry/4 SEASONS pastry)
- B - Aspiration tube Ø 16 (gelato/4 SEASONS gelato)
- SC - Condensate drain with 3/4" no return valve
- E - Electric power for display case
- EU - Electric power for remote CU

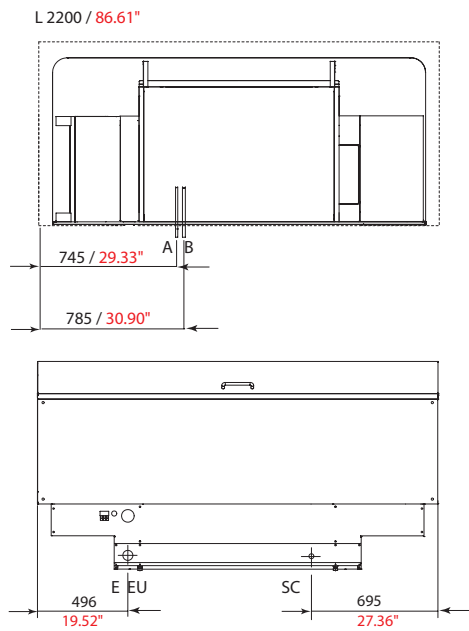
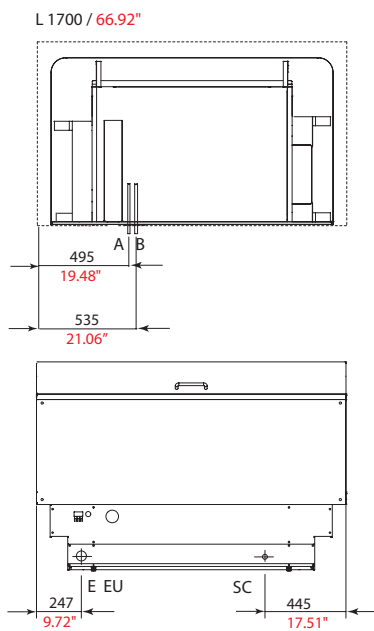
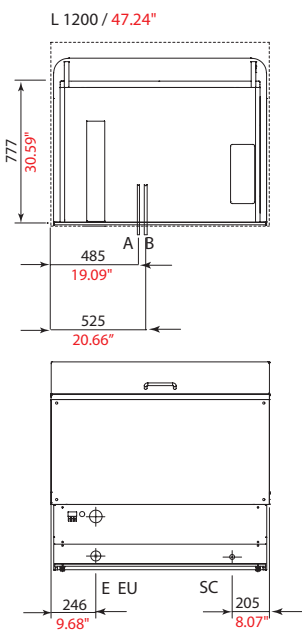



Cloud

VETRINA GELATO / 4 STAGIONI GELATO / 4-SEASONS DISPLAY CASE



MODULI E VASCHE GELATO | UNITS AND GELATO PANS LAYOUT

Modulo / Unit	L 1224		L 1724		L 2224		VASCETTA GELATO GELATO PAN 360x165 14.2"x6.5"	H 120 mm / 4.72"	5 litri / liters
	6+6	9+9	12+12						
360 x 165	L 1224		L 1724		L 2224		VASCETTA GELATO GELATO PAN 360x250 14.2"x9.8"	H 80 mm / 3.15"	5,5 litri / liters
	L 1224		L 1724		L 2224				
	L 1224		L 1724		L 2224				

DIMENSIONI - PESO - IMBALLO | DIMENSIONS - WEIGHT - PACKAGING

Modello Unit	Lunghezza con 2 fianchi Length with 2 side panels		Profondità Depth		Altezza Height		Peso Weight		Dimensioni imballo LxPxA Packaging dimensions LxDxH		Peso totale prodotto+imballo Total weight product+packaging	
	mm	in	mm	in	mm	in	kg	lb	mm	in	kg	lb
L 1200	1224	48.19	1018	40.08	1148	45.20	270	595	1330x1120xH1384	52,4"x44,1"xH 54,5"	321	708
L 1700	1724	67.87	1018	40.08	1148	45.20	375	827	1830x1120xH1384	72"x44,1"xH 54,5"	443	977
L 2200	2224	87.56	1018	40.08	1148	45.20	475	1047	2270x1120xH1384	89,4"x44,1"xH 54,5"	558	1230

DATI TECNICI | TECHNICAL DATA

CON MOTORE A BORDO (UC) WITH BUILT-IN AIR-COOLED CONDENSING UNIT (UC)								TENSIONE E FREQUENZA VOLTAGE AND FREQUENCY		400V/3+N/50Hz	
Modello Unit	Potenza assorbita Current consumption		Resa Cooling capacity		Cilindrata Displacement	Classe climatica Climate class		Temperatura di esercizio Operating temperature			
	W	A	W/H	BTU/h		°C	°F	U.R. R.H.	°C	°F	
GAS R452A			-30°C	-22°F	cm³			R.F. H.R.			
L 1200	2126	7.29	1580	5394	77,54	35°C	95°F	60%	-2°C;-18°C -2°C;-18°C 4°C;+8°C	+28.4°F;+0.4°F +28°F;+0°F +39°F;46°F	
L 1700	2569	8.82	2100	7169	99,7	35°C	95°F	60%	-2°C;-18°C -2°C;-18°C 4°C;+8°C	+28.4°F;+0.4°F +28°F;+0°F +39°F;46°F	
L 2200	3331	11.69	2500	8535	99,7	35°C	95°F	60%	-2°C;-18°C -2°C;-18°C 4°C;+8°C	+28.4°F;+0.4°F +28°F;+0°F +39°F;46°F	

CON MOTORE REMOTO ENTRO 20 METRI WITH CONDENSING UNIT WITHIN 20 METERS								TENSIONE E FREQUENZA VOLTAGE AND FREQUENCY		400V/3+N/50Hz	
Modello Unit	Potenza assorbita Current consumption		Resa Cooling capacity		Cilindrata Displacement	Classe climatica Climate class		Temperatura di esercizio Operating temperature			
	W	A	W/H	BTU/h		°C	°F	U.R. R.H.	°C	°F	
GAS R452A			-30°C	-22°F	cm³			R.F. H.R.			
L 1200	2527	9.15	2100	7169	99,7	35°C	95°F	60%	-2°C;-18°C -2°C;-18°C 4°C;+8°C	+28.4°F;+0.4°F +28°F;+0°F +39°F;46°F	
L 1700	3029	11,76	2780	9491	149,5	35°C	95°F	60%	-2°C;-18°C -2°C;-18°C 4°C;+8°C	+28.4°F;+0.4°F +28°F;+0°F +39°F;46°F	
L 2200	3197	12,5	2780	9491	149,5	35°C	95°F	60%	-2°C;-18°C -2°C;-18°C 4°C;+8°C	+28.4°F;+0.4°F +28°F;+0°F +39°F;46°F	





Cloud

VETRINA GELATO / 4 STAGIONI
GELATO / 4-SEASONS DISPLAY CASE



DATI TECNICI | TECHNICAL DATA

	<p>CON MOTORE A BORDO (UC) O REMOTO ENTRO 10 M WITH BUILT-IN CONDENSING UNIT (UC) OR WITH REMOTE CONDENSING UNIT WITHIN 10 M</p>	<p>TENSIONE E FREQUENZA VOLTAGE AND FREQUENCY</p>	<p>V/Ph/Hz 208-220/1/60</p>
--	--	---	--

Modello Unit	Potenza Comp. HP	Breaker size	MCA	MOP	Resa Capacity		Cilindrata Displacement	Classe climatica Climatic class			Temperatura di esercizio Operating temperature	
	W	A	A	A	W/H -30°C	BTU/h -22°F	cm ³	°C	°F	U.R. R.H. R.F. H.R.	°C	°F
GAS R404A												
L 1200	1,2	15	10	13	1085	3700	34,5	35°C	95°F	60%	-2°C; -18°C -18°C +8°C	+28.4°F; +0.4°F +28°F; +0°F +39°F; 46°F
L 1700*	1,2	25	17	25	1085+1085	3700+3700	34,5+34,5	35°C	95°F	60%	-2°C; -18°C -18°C +8°C	+28.4°F; +0.4°F +28°F; +0°F +39°F; 46°F
L 2200*	1,2	25	18	25	1085+1085	3700+3700	34,5+34,5	35°C	95°F	60%	-2°C; -18°C -18°C +8°C	+28.4°F; +0.4°F +28°F; +0°F +39°F; 46°F

* 2 compressori | * 2 condensing units

* 2 compressori | * 2 condensing units

